

TFC4-10X-L-XXXX

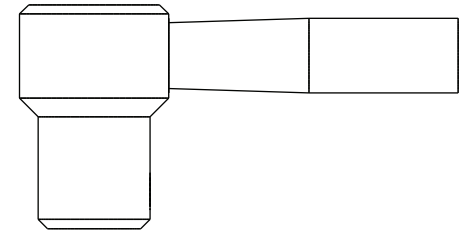

"L"

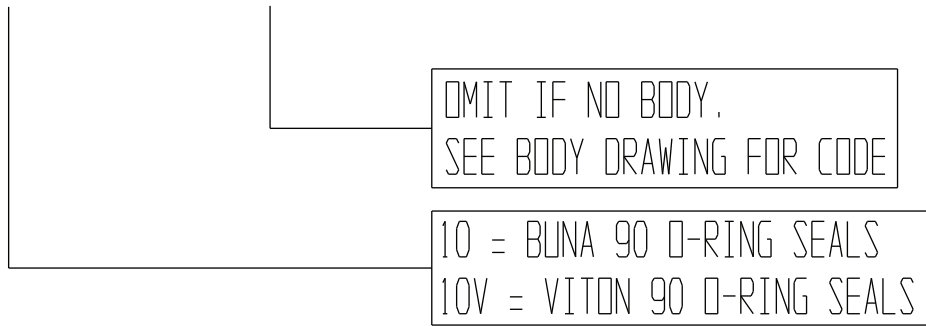
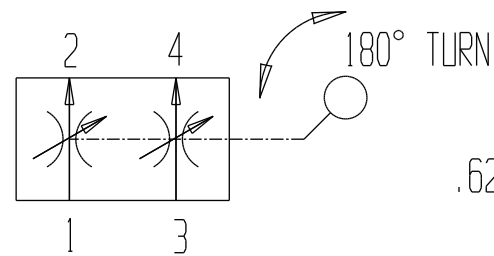
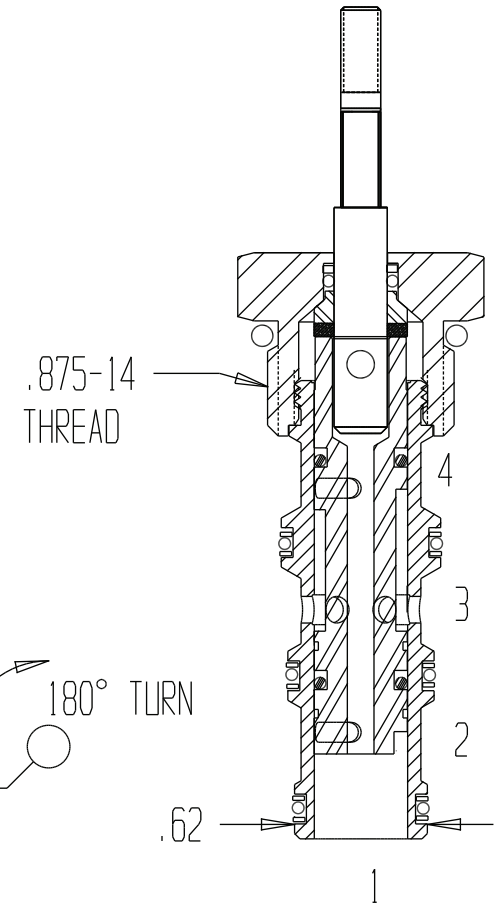

FUNCTIONAL SYMBOL

180° ROTARY TANDEM
FLOW CONTROL CARTRIDGE

GENERAL SPECIFICATIONS	
PRESSURE	5,000 PSI WORKING
FLOW RATE	7 GPM AT 100 PSI DIFFERENTIAL.
MEDIA	PETROLEUM MINERAL BASE SAE 20. OTHER BASES MAY REQUIRE SEAL CHANGES.
CAVITY	2141-10-4
SEAL KIT	5079 (BUNA), 5081 (VITON)
LEAKAGE - MAX.	INTERNAL-10 CUBIC INCHES/MIN., EXTERNAL-NONE.