

1413

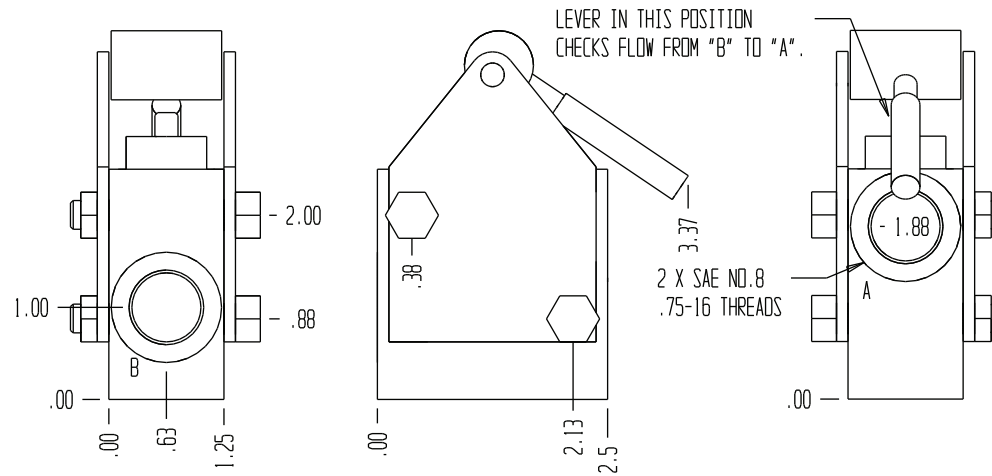

NORMALLY CLOSED CHECK VALVE WITH TOGGLE RELEASE. THE OVER-CENTER TOGGLE WILL HOLD THE VALVE OPEN. AN IDEAL APPLICATION SUGGESTION IS A "TRANSPORT LOCK". THIS CHECK REQUIRES A DIFFERENTIAL OF PRESSURE FROM PORT A TO PORT B TO BE 2:1 OR GREATER WHEN FLOW IS FROM A TO B.

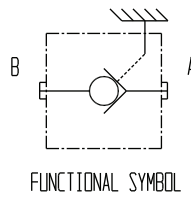

GENERAL SPECIFICATIONS	
PRESSURE	5,000 PSI WORKING
FLOW RATE	15
MEDIA	PETROLEUM MINERAL BASE SAE 20. OTHER BASES MAY REQUIRE SEAL CHANGES.
SEAL KIT	
LEAKAGE - MAX.	INTERNAL - 5 DROPS/MIN., EXTERNAL - NONE.