

3154-XXX

ORIFICE SIZE	FLOW RATE
031	1-2.5
062	2.5-5
070	5-7
113	7-10
140	10-12

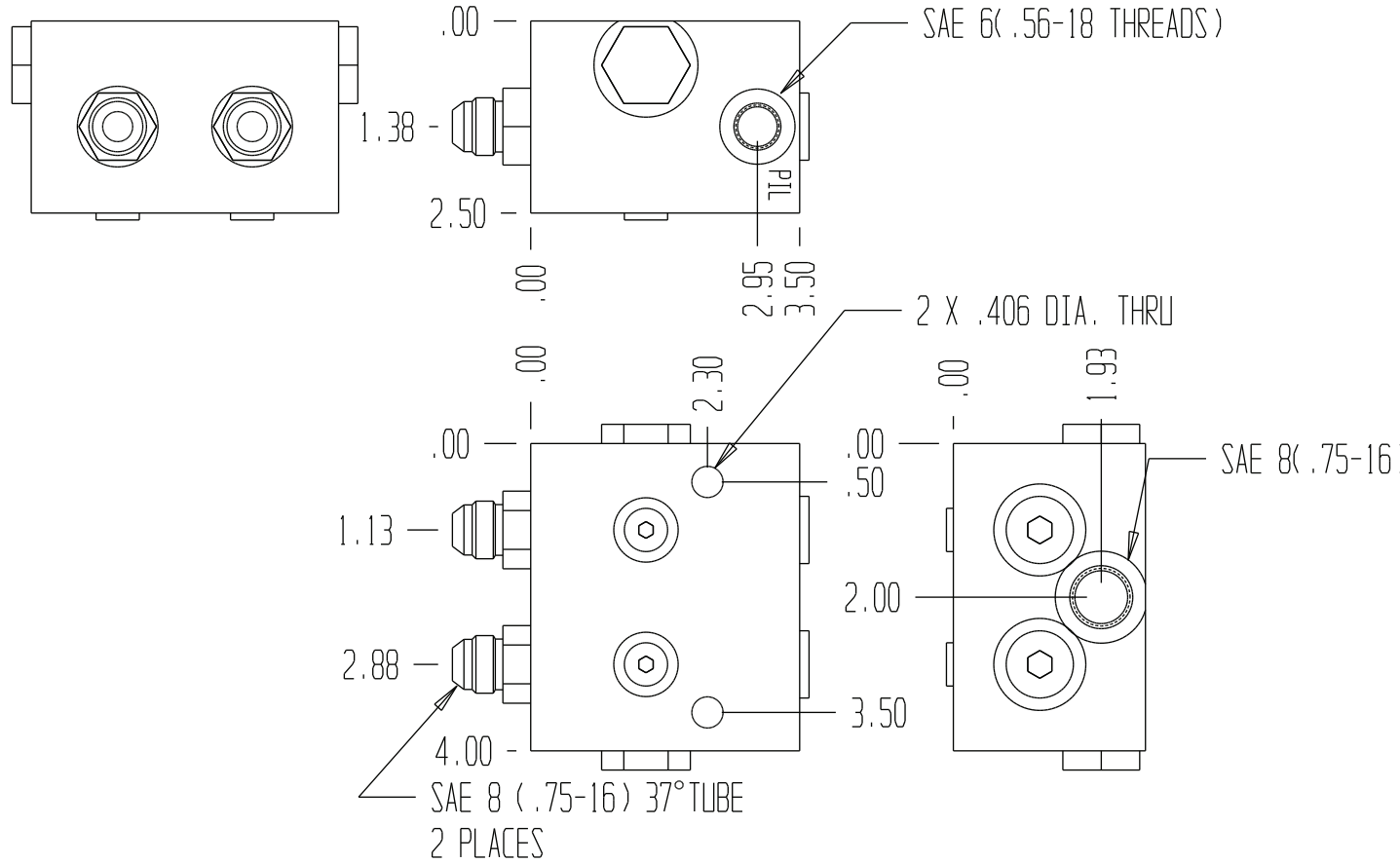

GENERAL SPECIFICATIONS	
PRESSURE	5,000 PSI WORKING
FLOW RATE	SEE CHART ABOVE
MEDIA	PETROLEUM MINERAL BASE SAE 20. OTHER BASES MAY REQUIRE SEAL CHANGES.
SEAL KIT	
LEAKAGE - MAX.	INTERNAL - 10 DROPS/MIN., EXTERNAL - NONE
CRACK PRESSURE	12 PSI. FOR CHECK CARTRIDGES
PILOT RATIO	4 : 1

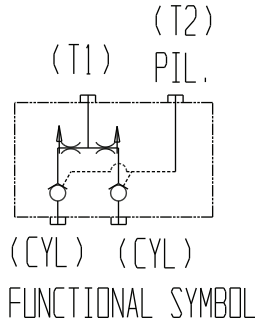

DIVIDE-COMBINE VALVE WITH LOAD HOLDING CHECKS IN THE CYLINDER PORTS.