

8064-XXX

ORIFICE SIZE	FLOW RATE
031	1-2.5
062	2.5-5
070	5-7
113	7-10
140	10-12

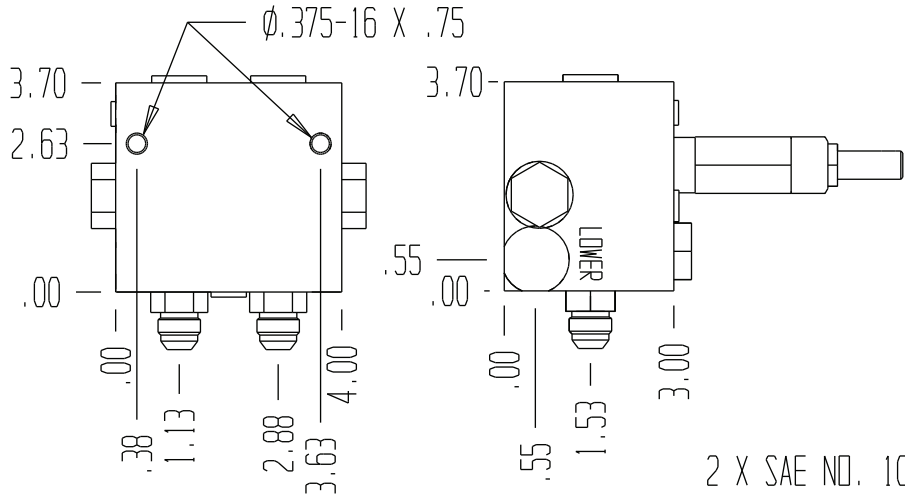

2 X SAE NO. 10
.875-14 THREAD

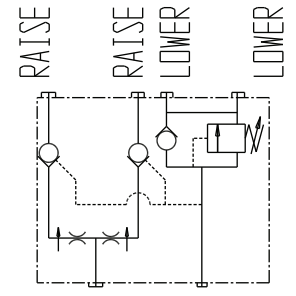
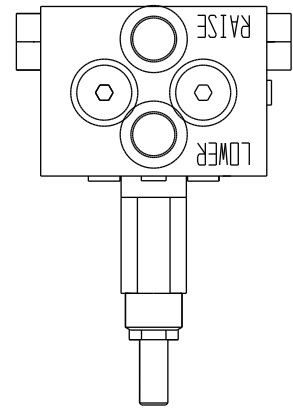

RAISE LOWER
FUNCTIONAL SYMBOL

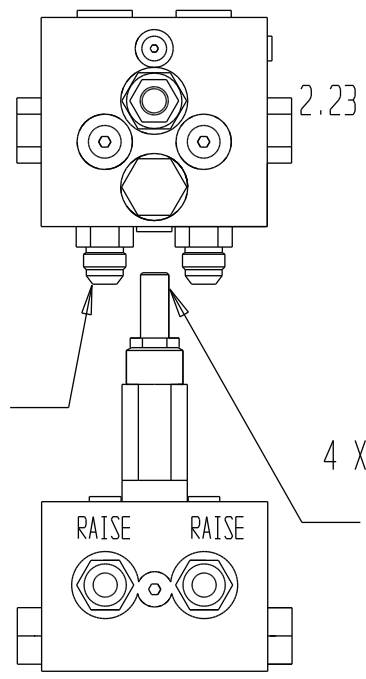

4 X SAE NO. 08 (Ø.75-16)

TURN THIS SCREW CLOCK-WISE TO INCREASE PILOT PRESSURE ON LOAD HOLDING CHECKS. THIS PREVENTS LOWERING CHATTER.

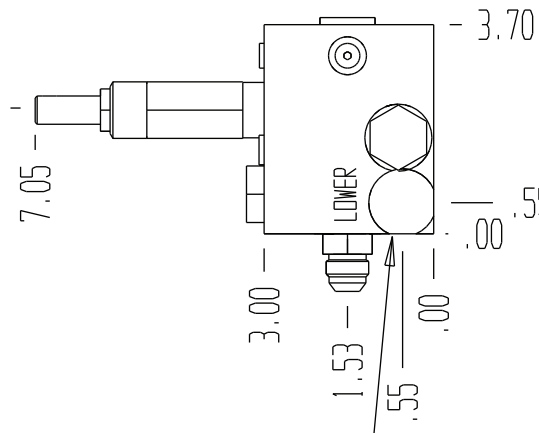

GENERAL SPECIFICATIONS	
PRESSURE	5,000 PSI WORKING
FLOW RATE	SEE DRIFICE CHART ABOVE
MEDIA	PETROLEUM MINERAL BASE SAE 20. OTHER BASES MAY REQUIRE SEAL CHANGES.
SEAL KIT	
LEAKAGE - MAX.	INTERNAL - 10 DROPS/MIN., EXTERNAL - NONE
CRACK PRESSURE	12 PSI. FOR CHECK CARTRIDGES
PILOT RATIO	4 : 1

DIVIDE COMBINE VALVE. THIS VALVE HAS LOAD HOLDING 'PILOT TO OPEN' CHECKS. THE PILOT PRESSURE TO OPEN THE CHECK VALVES IS ADJUSTABLE.