

# 8258

## 10 SERIES DOUBLE PILOT CHECK

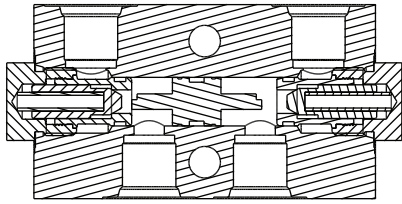

SECTION A-A

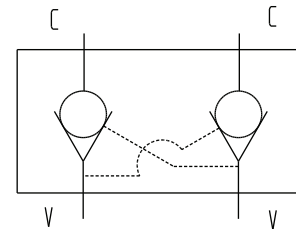
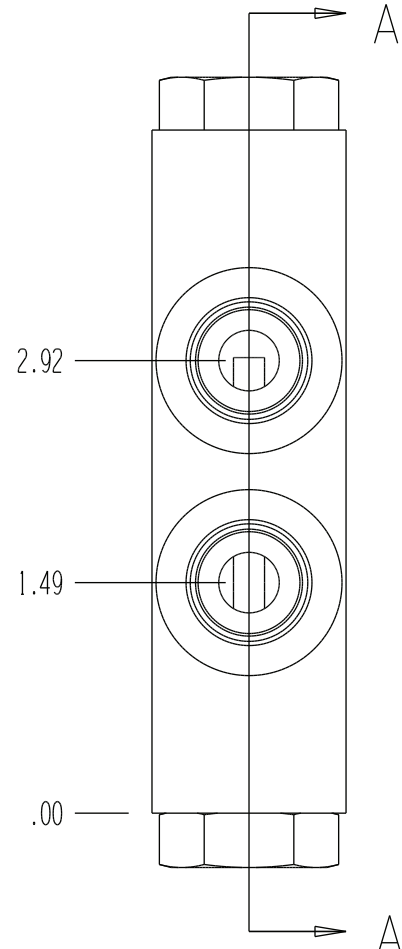
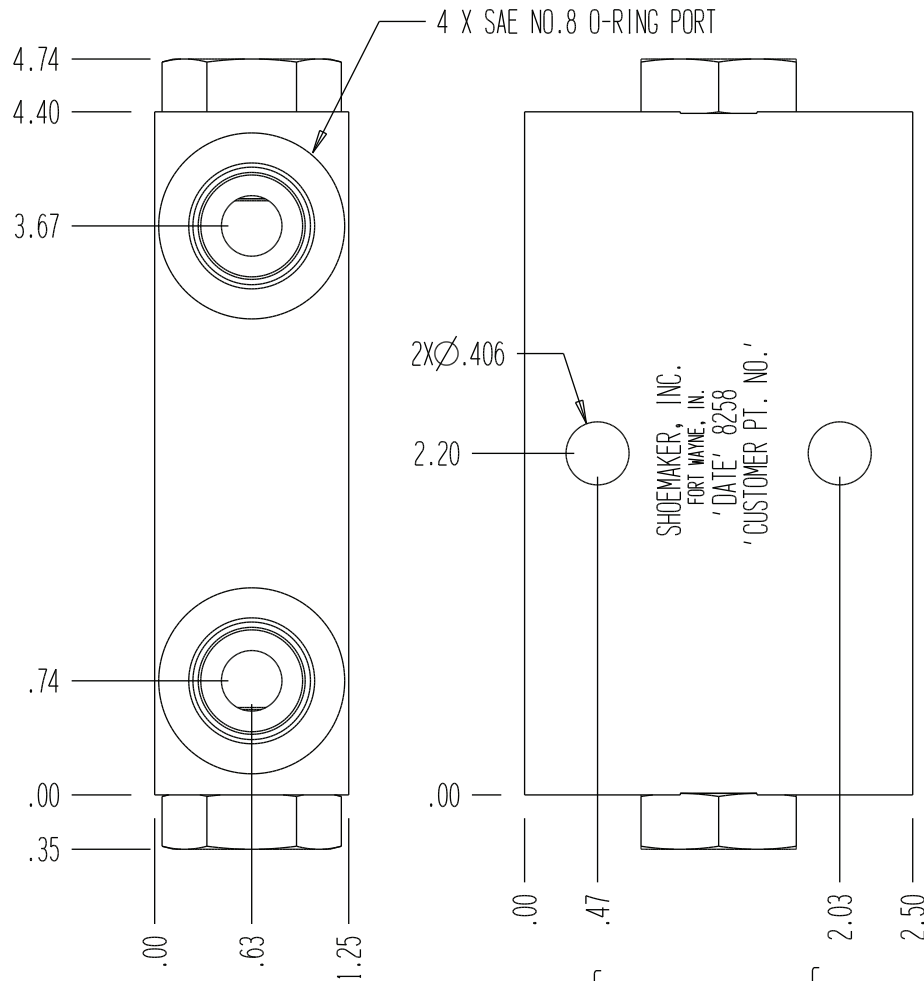

GENERAL SPECIFICATIONS	
PRESSURE	5,000 PSI WORKING
FLOW RATE	10 GPM AT 100 PSI DIFFERENTIAL.
MEDIA	PETROLEUM MINERAL BASE SAE 20. OTHER BASES MAY REQUIRE SEAL CHANGES.
CAVITY	2141-10-2
SEAL KIT	1400-BUNA
LEAKAGE	INTERNAL- 2 DROPS/MIN., EXTERNAL-NONE.
POPPET DISP.	.55